

INSTALLATION & CLEANING INSTRUCTIONS
HARLEY-DAVIDSON SPORTSTER
MODEL'S 215 & S215
2004 to Present

PARTS INVENTORY

<u>Item</u>	<u>Quantity</u>
1 7/8" Hex Spool Bolt Assembly	2
1 1/2" Hex Spool Bolt Assembly	2
1/8" x 5/16" Aluminum Spacer	4
Chrome Caps	4
Silicone	1
TURN SIGNAL RELOCATION KIT includes:	
30" wire	
Wire Connectors	4
Turn Signal Relocation Bracket	1
1/4" - 20 X 3/4" Hex Cap Screws	2
1/4" Flat washers	4
1/4" - 20 Locknuts	2
5/16" - 18 X 3/4 Hex Cap Screws	2
5/16" Star Washers	2
8 x 22 x 5mm Black Plastic Spacers	2
3/16 x 1/16 x 5/16 rubber grommets	2

DISASSEMBLY

1. Refer to Figures 1 & 2.
2. Remove taillight and remove seat.

SAFETY: DISCONNECT BATTERY PRIOR TO ALL WIRING MODIFICATIONS

3. Disconnect Right turn signal connector inside taillight. Pull wire from the underside of fender. Cut the wire approximately 2 inches from the connector,

save for reinstallation. Ensure the wires are loose from all retaining clips under fender.

4. Remove nut located behind fender holding the turn signal.
5. On the right side only, Remove the two torx bolts from fender strut, carefully pull and rotate fender strut cover to remove. Pull turn signal wire completely out. Remove bolt holding turn signal to the fender strut cover.

SADDLEBAG INSTALLATION

6. Reinstall the fender strut cover using the 1 7/8" Hex Spool Bolt Assembly and 1/8" x 5/16" Aluminum Spacer in the front hole and the 1 1/2" Hex Spool Bolt Assembly and 1/8" x 5/16" Aluminum Spacer in the rear hole. Refer to view "B". Insert the chrome caps into the existing turn signal holes. Bend tabs over to ensure a snug fit.
7. Repeat disassembly and installation on opposite side.

TURN SIGNAL RELOCATION

8. Install turn signal bracket between license plate and license plate bracket with ears of bracket facing the front of the motorcycle, using 1/4 - 20 x 3/4 Hex cap screws, 1/4 flat washers, and 1/4 - 20 locknuts.
9. Mount turn signals directly to bracket using 5/16 - 18 x 3/4 hex cap screws with a Black Plastic Spacer, and 5/16 star washer. For a clean installation slide rubber grommet over the wire and secure into hole in turn signal, remove top center mounting bolt on license plate bracket and run wires through this hole. Splice the connector back on the wire, and reconnect to wire harness. Ensure all wires are secure under fender. Reinstall taillight.
10. Connect battery and test turn signals for function.

Information: Bags will be easier to mount and remove if a small amount of silicone lubrication is applied to rubber mounting points.

11. Mount saddlebags over spools on fender strut and secure with clips retained inside bags.
12. Inspect each clip to verify each clip is properly seated in retaining groove. See View "A".

13. Reinstall seat.

SADDLEBAG CARE INSTRUCTIONS

- Do not exceed 20 lbs. per saddlebag this includes sitting or standing on bags, it is a common occurrence for a non-rider to attempt to sit on bags, this also may void warranty.
- Periodically, apply a small amount of silicone lubrication to rubber mounting points. Saddlebags will be easier to mount and remove.
- Remove grease, oil or mud with mild detergent and water. For fast touch-up, *Windex* or *Turtle Wax F-21* will restore original luster. The use of any other chemicals may discolor the saddlebags.
- Whenever possible, release locks on saddlebag lids to allow the gaskets to expand during storage.
- If you use bags to ice down drinks, later remove bags, drain water and blot up excess water. The foam interior lining is closed-cell foam and does not retain water. Leave lids open until interiors are dry.
- Use white *Scotch Brite* scour pad (ultra-fine, only) to remove scratches & shiny spots and restore luster. This can be purchased at an automotive supply store.
- When locking or unlocking saddlebags, place one hand on top of bag near lock and apply a moderate amount of down pressure while turning the key. This compresses the weather-seal enabling the locking mechanism to turn freely.
- Always inspect to verify each of the saddlebag mounting clips on inside of bag is properly installed when mounting bags. Clips fit into groove on mounting spool. Failure to perform this correctly can cause severe damage and may void warranty.

INSTALLATION INSTRUCTIONS HARLEY-DAVIDSON SPORTSTER Model # S215 & 215

Figure 2

← FRONT

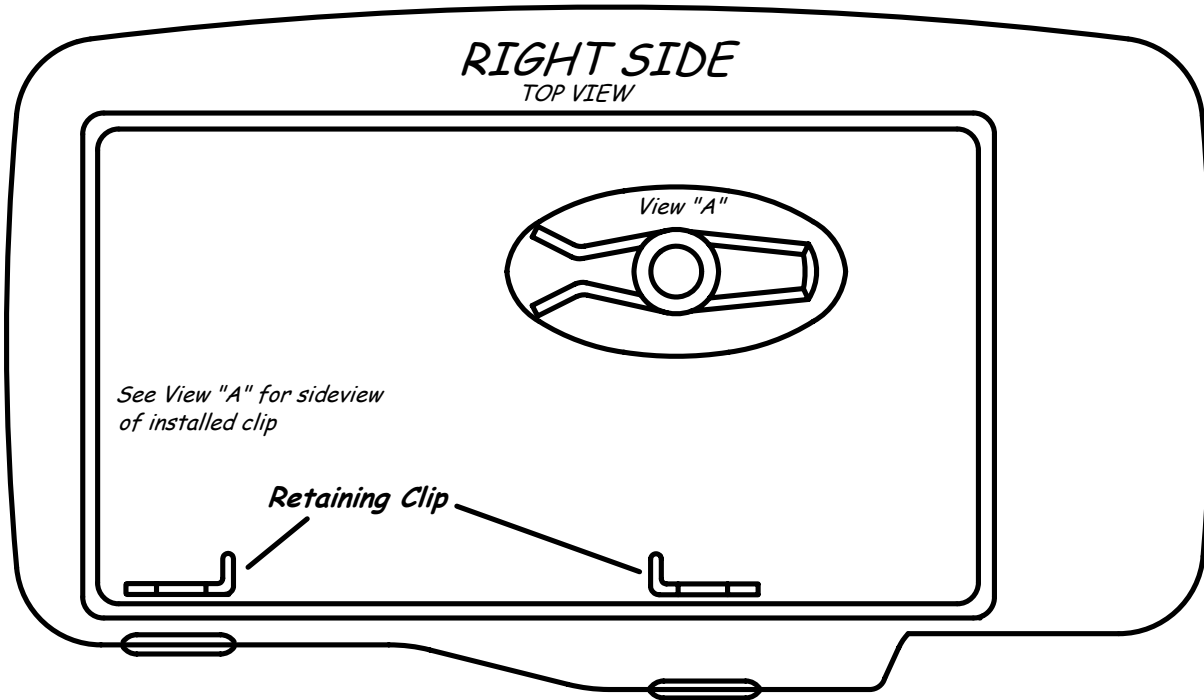

1 7/8" Hex Spool Bolt Assembly



1/8" x 5/16" Aluminum Spacer

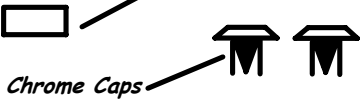

Chrome Caps

1 1/2" Hex Spool Bolt Assembly

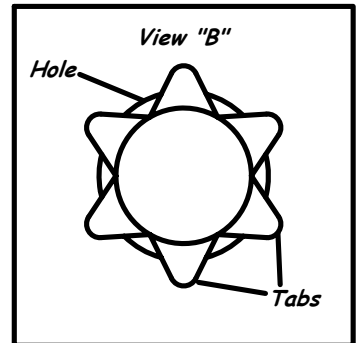

Underside of Fender Brace Cover

Fender Brace

Fender

02/16/09

Turn Signal Relocation Harley Davidson Sportster 2004 to Present

Figure 1

